

---

Meridian 1

# **DASS2**

## Product Overview Guide

---

Document Number: 553-3911-100

Document Release: Standard 6.00

Date: April 2000

---

Copyright © 1992–2000 Nortel Networks  
All Rights Reserved

Printed in Canada

Information is subject to change without notice. Nortel Networks reserves the right to make changes in design or components as progress in manufacturing and engineering may warrant. Please consult with your Nortel Networks representative regarding market specific regulatory requirements.

SL-1 and Meridian 1 are trademarks of Nortel Networks.



## Revision history

---

**April 2000**

Standard 6.00. This is a global document and is up-issued for X11 Release 25.0x.

**October 1997**

Issue 5.00 released as Standard for Generic X11 Release 23.0x. With this release, the feature descriptions previously contained in this Nortel Networks technical publication (NTP) were removed. Information about DASS2 features can be found in the DASS2 Features and Services Guide 553-3911-300.

**August 1996**

Issue 4.00 released as Standard for Generic X11 Release 22.0x.

**December 1995**

Issue 3.00 released as Standard for Generic X11 Release 21.1x.

**May 1994**

Standard version issued for Generic X11 Release 20.

**July 1993**

Standard version issued for Group H (Phase 8B).

**October 1992**

Standard version issued for Group G (Phase 7C).



---

# Contents

---

<b>About this guide</b> .....	<b>7</b>
Reference list .....	7
Applicability of this guide .....	8
How this guide is organized .....	8
Related documents .....	9
DASS2 documents: .....	9
DPNSS1 documents: .....	9
ISDN documents: .....	9
Meridian 1 documents: .....	9
<b>Description of DASS2</b> .....	<b>11</b>
Reference list .....	11
DASS2 .....	11
DASS2 application principles .....	15
Transmission System .....	15
Link Designation .....	15
PBX Functions .....	15
Configuration of trunks .....	16
DASS2 and the Meridian 1 .....	18
Channels .....	18
Interworking with other signaling systems .....	19
DASS2 to ISDN PRA gateway .....	19
DASS2 to ISDN BRI, QSIG, and EuroISDN gateway .....	20
Gateway interworking with other signaling systems .....	21
Numbering plans for DASS2 routes .....	22

Incoming DDI Numbering Facilities .....	22
Incoming Non-DDI Numbering Facilities .....	23
Dialed Number Identification Service - DNIS .....	24
Network Routing of DASS2 Calls .....	24
DASS2 - Line Identities .....	24
Example of a DASS2 Numbering Scheme .....	25
Dialing Network Numbers .....	26
Dialing PSTN Numbers .....	28
Special Numbers .....	29
Routing of DDI Calls .....	35
Programming for ISDN Line Identities .....	35
<b>Hardware requirements .....</b>	<b>37</b>
DASS2 hardware requirements .....	37
Engineering note pertaining to port addressing modes .....	41

---

# About this guide

---

## Reference list

The following are the references in this section:

- *Traffic Measurement Formats and Output (553-2001-450)*
- *Basic and Network Alternate Route Selection Description (553-2751-100)*
- *ISDN PRI Installation (553-2901-201)*
- *ISDN PRI/BRI Feature Description and Administration (553-2901-301)*
- *ISDN PRI Maintenance (553-2901-501)*
- *Meridian 1 System Overview (553-3001-100)*
- *Meridian 1 System Installation Procedures (553-3001-210)*
- *X11 Features and Services (553-3001-306)*
- *Meridian 1 General Maintenance Information (553-3001-500)*
- *DASS Installation Guide (553-3911-200)*
- *DASS Features and Services Guide (553-3911-300)*
- *DASS Maintenance Guide (553-3911-500)*
- *DPNSS1 Product Overview Guide (553-3921-100)*
- *DPNSS1 Installation Guide (553-3921-200)*
- *DPNSS1 Features and Services Guide (553-3921-300)*
- *DPNSS1 Maintenance Guide (553-3921-500)*

The DASS2 Product Overview Guide is part of the suite of Nortel Networks technical publications (NTPs) designed specifically for DASS2 applications.

This guide provides descriptive information on all relevant components of DASS2 functionality, such as application protocols and principles, hardware and software requirements.

## Applicability of this guide

The intended audience of the DASS2 Product Overview Guide is network data managers, design personnel, marketing personnel, and anyone requiring a general information base for DASS2 functionality.

## How this guide is organized

The DASS2 Product Overview Guide has been arranged in the following sections:

- *Description of DASS2* - describes DASS2 signaling protocols; describes channels and channel configurations; explains and illustrates DASS2 dialing plans and concepts.
- *Hardware requirements* - lists and describes the hardware and configuration of DASS2 links.



## Related documents

Refer to the following documents for additional information:

### **DASS2 documents:**

- BTNR 190 Requirements Document
- *DASS Installation Guide (553-3911-200)*
- *DASS Features and Services Guide (553-3911-300)*
- *DASS Maintenance Guide (553-3911-500)*

### **DPNSS1 documents:**

- BTNR 188 Requirements Document
- *DPNSS1 Product Overview Guide (553-3921-100)*
- *DPNSS1 Installation Guide (553-3921-200)*
- *DPNSS1 Features and Services Guide (553-3921-300)*
- *DPNSS1 Maintenance Guide (553-3921-500)*

### **ISDN documents:**

- *ISDN PRI Installation (553-2901-201)*
- *ISDN PRI/BRI Feature Description and Administration (553-2901-301)*
- *ISDN PRI Maintenance (553-2901-501)*

### **Meridian 1 documents:**

- *Meridian 1 System Installation Procedures (553-3001-210)*
- *Meridian 1 General Maintenance Information (553-3001-500)*
- *X11 Features and Services (553-3001-306)*
- *Basic and Network Alternate Route Selection Description (553-2751-100)*
- *Meridian 1 System Overview (553-3001-100)*
- *Traffic Measurement Formats and Output (553-2001-450)*



---

# Description of DASS2

---

## Reference list

The following are the references in this section:

- *ISDN PRI Installation (553-2901-201)*
- *ISDN PRI/BRI Feature Description and Administration (553-2901-301)*
- *ISDN PRI Maintenance (553-2901-501)*
- *X11 Features and Services (553-3001-306)*
- *DPNSS1 Product Overview Guide (553-3921-100)*

## DASS2

British Telecom's Digital Access Signaling System No.2 (DASS2) is the signaling protocol defined for PBX access to the Integrated Services Digital Network (ISDN). In the United Kingdom, DASS2 provides

- digital access for PBX to (U.K.) ISDN for voice and data calls
- supplementary facilities, such as Call Charge Indication and Calling Line Identity
- TIE line user-to-user signaling facility, allowing semi-permanent private networking connections to be established between PBXs, via ISDN

DASS2 is specified in terms of the International Standards Organization (ISO) reference model for Open Systems Interconnection (OSI). Level 1 (Physical) of the model is a 2.048 Mbit/s digital interface and level 2 (Data Link) is the Link Access Protocol (LAP) defined for DASS2. Level 3 (Network) is the message layer unique to DASS2. Figure 1 illustrates the OSI model.

**Figure 1**  
**How the OSI Model works**

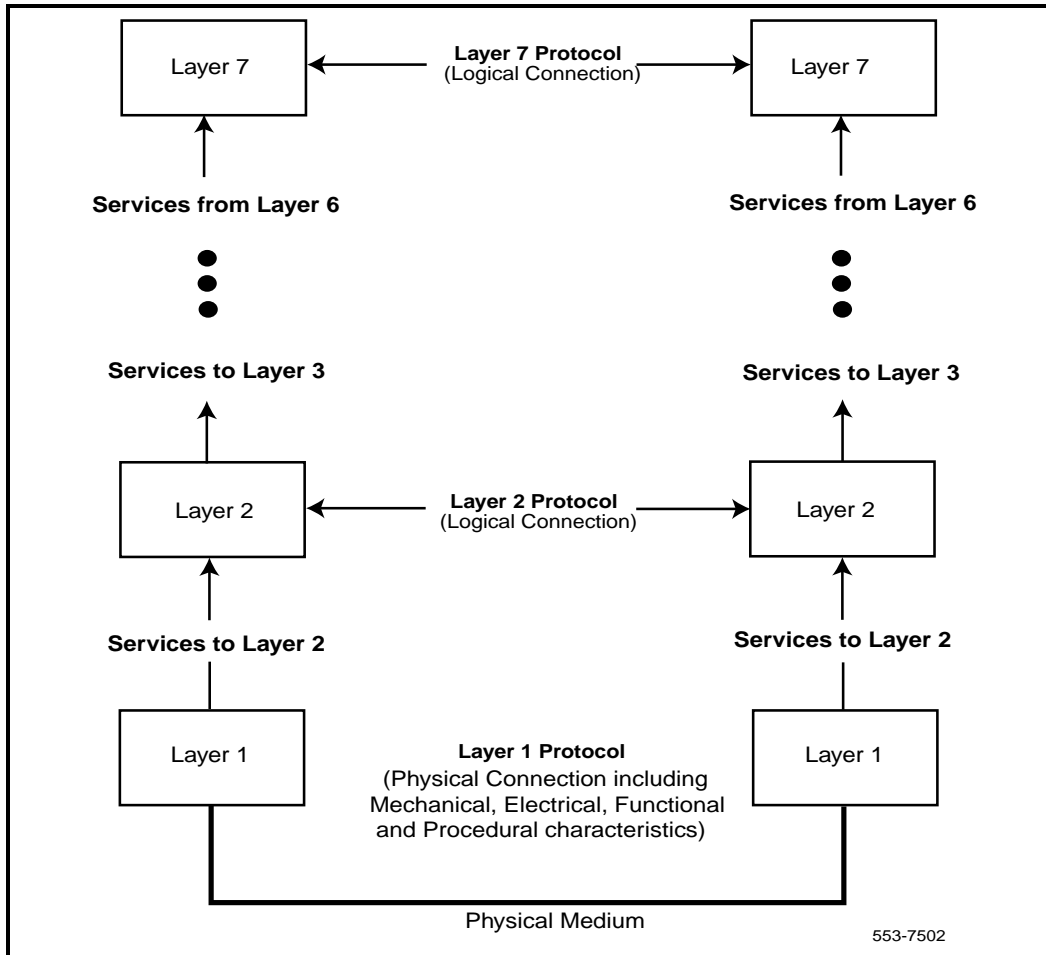

Each layer in the model depends on the services offered by the layer below it and, in turn, builds on those services to perform a specific set of communications functions. Protocols are the mechanism by which each layer accomplishes its communications functions. It then offers these functions to the layer above it in the form of its own set of services. Note that, while services are used between layers within a signaling entity (switch), protocols operate within the same layer of the OSI model but between different signaling entities.

The OSI layering approach effectively divides the complex task of communication between network signaling entities into a series of more easily manageable pieces, each of which can be modified without affecting the other pieces. This allows more flexible evolution and compatibility with the ongoing standards activities.

Figure 2 shows the structure of the OSI Model and describes the functions of each layer.

**Figure 2**  
**The structure of the OSI Model together with the functions of each layer**

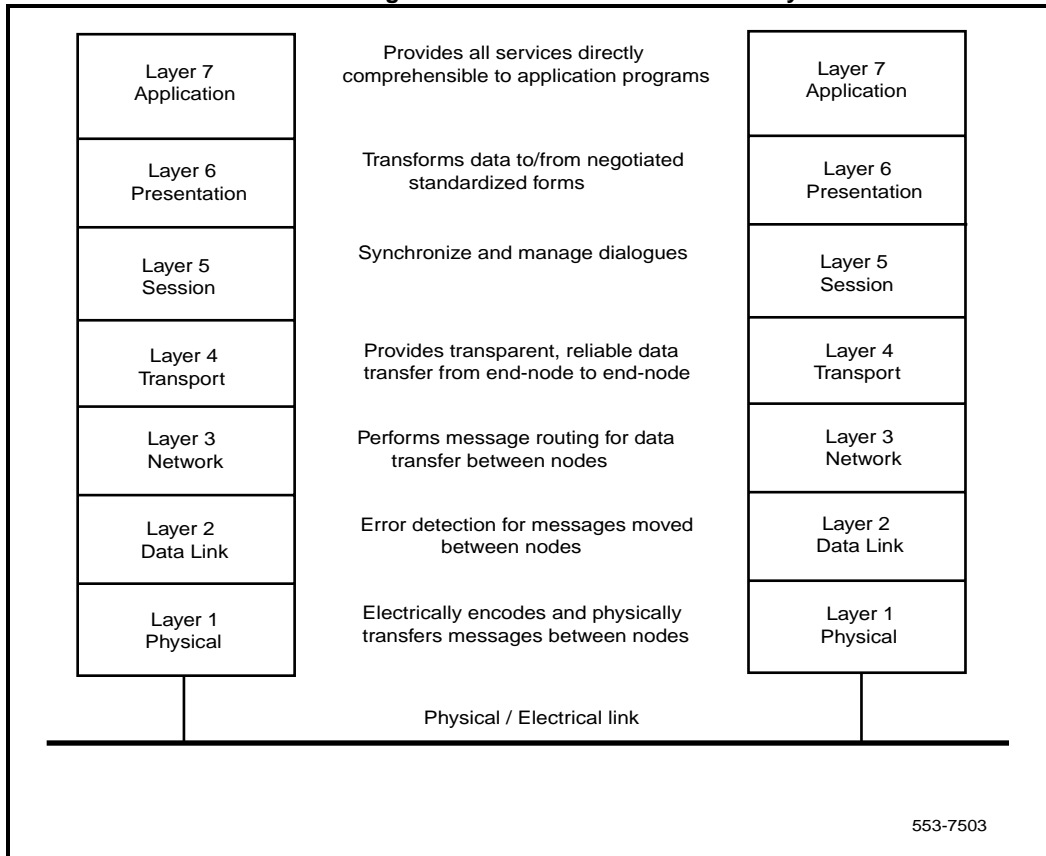

## DASS2 application principles

### Transmission System

The 2.048 Mbit/s digital transmission is divided into 32 timeslots, numbered 0-31. Timeslots 1-15 and 17-31 provide 30 traffic channels. Timeslot 0 is used as a synchronization channel. DASS2 is a message-based signaling system that uses a common signaling channel in timeslot 16. Each traffic channel has an associated LAP. The LAPs operate in parallel over the signaling channel. Various messages are defined; each message has mandatory data elements and may include additional optional information.

*Note:* British Telecom (BT) numbers the traffic channels 1-30 (that is, timeslot 17 and LAP 17 are associated with traffic channel 16), but in the NT implementation the timeslot numbers are used to number the traffic channels.

Each traffic channel, together with its LAP, represents one trunk and can be used for a call independently of the other channels for an incoming or outgoing call.

Each 2.048 Mbit/s link must be connected to an ISDN local public exchange. Some channels on the link may be configured to support the TIE Line Signaling facility, which allows a DPNSS1 connection to be established between PBXs through the public ISDN.

### Link Designation

The ends of each inter-PBX link are labelled arbitrarily A and B, and the ends of each DASS2 channel are designated X and Y. The X end has priority if both ends attempt to use the channel at the same time.

### PBX Functions

A PBX that connects a DASS2 channel to or from a non-DASS2 device is termed an end PBX. If that device is a trunk, then the PBX is termed a gateway. A PBX connecting two DASS2 channels is a transit.

## Configuration of trunks

DASS2 trunks are configured using the same route and member method used for other trunks, thus:

- any number of routes may be associated with the same link
- a route may be associated with any number of links
- each route member must be assigned to one channel
- Not all channels need to be associated with members. These non-associated channels cannot, however, be used for calls.
- members and channels must be numbered separately
- Members are screened for outgoing calls using a linear search (Sequential Line) or round robin (Cyclic Line). For DASS2 links, a linear search should be used.
- each route may be configured only for incoming calls, only for outgoing calls, or for both
- each route must be configured with DASS2 channels only

Figure 3 shows a typical DASS2 system configuration with a Q.931-to-DASS2 gateway, a DPNSS1-to-DASS2 gateway, and the major public exchange types to which DASS2 connectivity is supported.



Figure 3  
A typical DASS2 system configuration

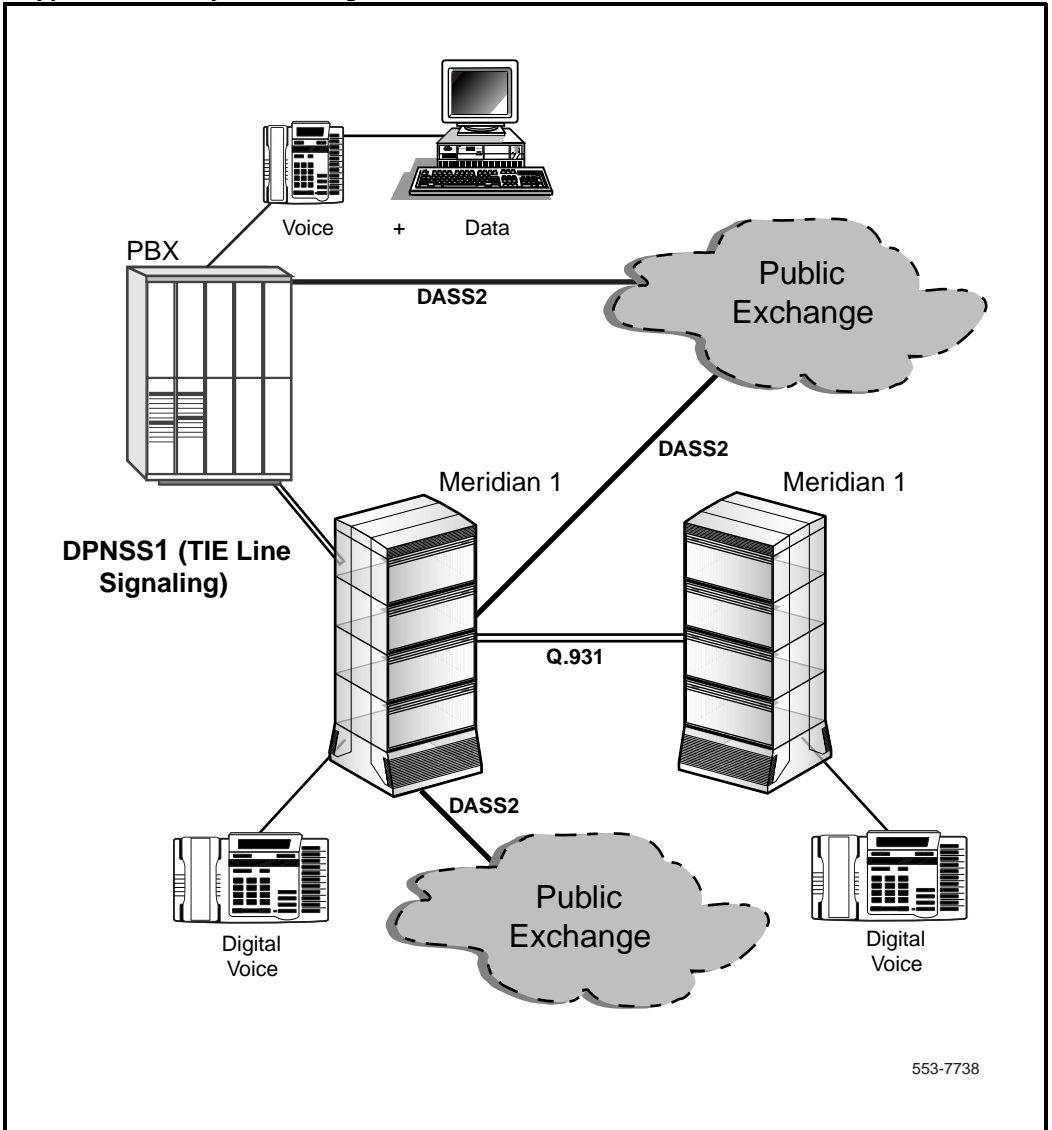

553-7738

## DASS2 and the Meridian 1

DASS2 is the standard UK protocol for 2Mbit/s connections between PBXs and British Telecom's ISDN. DASS2 functionality was provided on the Meridian 1 for its initial launch into the UK market. In keeping with the product development philosophy for Meridian 1, full interworking is provided between DASS2 and the following signaling interfaces:

- Q.931 MCDN interface
- Q.931 public ISDN access interface
- DPNSS1 private networking interface

## Channels

Within the DASS2 intelligent networking environment, a channel is a circuit that carries information between two PBXs via digital links. There are two types of channels — Bearer channels (B-channels) and Data channels (D-channels). The Bearer Channel (B-channel) is a digital trunk route carrying data/voice information — call processing signaling information is *not* carried over a B-channel. Voice and data transmission over DASS2 links is done at a rate of 64 Kbit/s. There may be up to 30 B-channels per D-channel.

The Data Channel (D-channel) carries call processing information between PBXs for the associated B-channels (call set-up and tear-down information, network feature activation information). The format is a High Level Data Link Control frame. For DASS2 applications, the D-channel must be a 64 Kbit/s digital channel. It may exist on the same or different carrying medium as the B-channels that it supports. One D-channel may support up to 30 B-channels.

Refer to Figure 4 for a depiction of how channels are typically configured for a DASS2 system.

**Figure 4**  
**Channel configurations for DASS2**

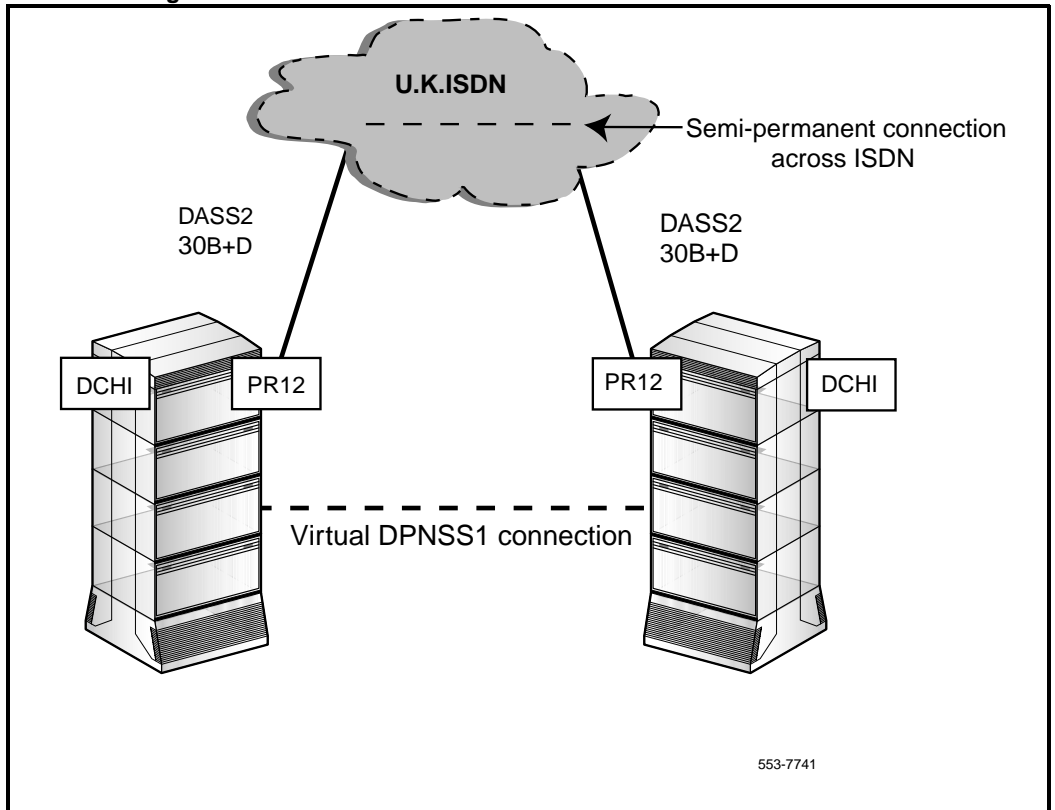

## Interworking with other signaling systems

### DASS2 to ISDN PRA gateway

The preferred method of interconnection between Meridian 1 PBXs and other products in the Meridian family is the Q.931 intelligent private network signaling protocol (please refer to the Nortel Networks technical publications *ISDN PRI Installation (553-2901-201)*, *ISDN PRI/BRI Feature Description and Administration (553-2901-301)*, *ISDN PRI Maintenance (553-2901-501)* for information on international ISDN PRI functionality on the Meridian 1). Similarly, the preferred option for providing an intelligent 2Mbit/s digital connection to the ISDN public network is using the Q.931 interface.

A gateway is a means of connecting two different signaling schemes. DASS2 on the Meridian 1 offers transparent gateway working to the Q.931 signaling protocols, with the following functions:

- Basic Call Service
- Calling Line Identification
- Called Line Identification
- Display update on call diversion
- Call Charging Indication
- Coordinated Dialing Plan

### **DASS2 to ISDN BRI, QSIG, and EuroISDN gateway**

The following services are provided with the DPNSS1 to ISDN BRI (line and trunk applications), QSIG, and EuroISDN gateways:

- Basic Call Service (3.1 kHz, speech, 64 Kbit/s restricted/ unrestricted digital information)
- Overlap Sending and Receiving
- 64 Kbit/s bearer capability

## Gateway interworking with other signaling systems

Table 1 outlines the gateway workings between DASS2 and other signaling systems, as well as the DASS2 services offered across the gateway.

**Table 1**  
**DASS2 gateway to other signaling systems**

<b>DASS2 Gateway to Signaling System</b>	<b>Yes/No</b>
PSTN	Yes
DPNSS1	Yes
Q.931 (Meridian 1 to Meridian 1)	Yes
Private ISDN/QSIG (ETS 300 172)	Yes
BRI line and trunk interface (NET3 compliant)	Yes
EuroISDN	Yes
10pps	Yes
SSMF5	No
<b>Non-gateway able to make and receive calls to:</b>	<b>Yes/No</b>
PSTN	Yes
DPNSS1	Yes
10pps	Yes
SSMF5	Yes

The DASS2-DPNSS1 gateway supports the following services:

- speech and data calls; outgoing calls are made at category 1 or category 2, as appropriate
- calling/called line identification

## Numbering plans for DASS2 routes

With the exception of DPNSS Trunk Identities, there is very little difference between DASS2 routes and standard Direct Dial In (DDI)/Exchange routes where numbering is concerned. For outgoing calls, DASS2 routes may be accessed by:

- dialing the route access code
- Coordinated Dialing Plan (Trunk Steering Code)
- NARS/BARS Special Numbers
- pre-translation giving any of the above

Examples of numbering plans which give access to DASS2 are presented in a section which follows.

### Incoming DDI Numbering Facilities

If a DASS2 route is configured as DDI, then incoming routing digits will be received. These routing digits correspond with a DDI extension number of an extension on the private network. The received digits may not be the same as the internal extension number. Three facilities exist which allow conversion of the received digits before they are presented to the digit translator:

- Digit Insertion - INST
- DDI Incoming Digit Conversion - IDC
- Pre-translation - PREXL

#### **Digit Insertion - INST**

A fixed string of up to 8 digits, programmable on a route basis, may be inserted in front of any received digits on an incoming call.

#### **DDI Incoming Digit Conversion - IDC**

This feature allows the private network numbering plan to differ from the public numbering plan with respect to DDI extensions within the private network. Each DDI route may have a unique IDC table assigned to it which will allow full or partial conversion of the received DDI digits. For more details please refer to the Nortel Networks technical publication *X11 Features and Services (553-3001-306)*.

### **Pre-translation - PREXL**

This feature allows the first dialed digit of a call to be pre-translated according to a table associated with the terminal originating the call. A table has 10 entries, one for each possible leading digit, 0 to 9. For each entry, one of four pretranslation options is possible:

- 1 Block the call
- 2 Delete the leading digit
- 3 Pass the leading digit unchanged
- 4 Replace the leading digit by another digit sequence up to four digits in length

The result of the pre-translation is then processed as a normal directory number.

All trunks are assigned table 0 (1 is reserved for consoles, and 2-255 for set groupings). For more details, please refer to the Nortel Networks technical publication *X11 Features and Services (553-3001-306)*.

## **Incoming Non-DDI Numbering Facilities**

If a DASS2 route is configured as non-DDI, then operation is much the same as for a standard Exchange Line route. Incoming calls will usually be routed directly to the attendant. The Meridian 1 offers the following alternative methods of termination:

- Auto-terminate
- Private Line

### **Auto-terminate**

If a route is defined as an auto-terminate route, then each trunk member of the route can be assigned an auto-terminate DN. Any incoming calls on the trunk will then be routed to this DN. This feature can be applied to DDI as well as non-DDI DASS2 trunks.

### **Private Line**

This feature applies to non-DDI routes only. For incoming calls, it offers the same facility as Auto-terminate, that is, termination on a pre-assigned DN. For outgoing calls, a given trunk can only be accessed from the extension on which the assigned DN is located.

## Dialed Number Identification Service - DNIS

DDI routes using auto-terminate or IDC may also be defined as DNIS routes. Dialed Number Identification Service (DNIS) is an Automatic Call Distribution feature designed to enhance call handling speed and quality. When used with an auto-terminate DDI route, DNIS allows the actual received digits and name to be displayed on the answering ACD agent. This can be used to indicate the service which the caller expects from the agent. If a route is configured as DNIS, then digit insertion and pre-translation may not be applied. Also, the number of digits which must be received on a DDI route is determined by the ISDN, and this may differ from the quantity defined for DNIS display purposes on the Meridian 1 system.

## Network Routing of DASS2 Calls

Incoming DDI DASS2 calls may be routed through the private network on DPNSS1 or non IDA trunks. To achieve this, the received digits must be converted into the appropriate CDP steering code or BARS Special Number.

Outgoing calls on DASS2 routes can be originated from DPNSS1 trunks. The way to configure this type of access is described in the Network Numbering section of the Nortel Networks technical publication *DPNSS1 Product Overview Guide (553-3921-100)*.

## DASS2 - Line Identities

### ISDN Access Code

Any ISDN Line Identities to be displayed on the Meridian 1 must be preceded by the "ISDN Access Code". This is defined in the customer data block. It must be defined at each network node which has access to the ISDN, either locally or through the DPNSS1 network.

### Provision of Line Identities to the ISDN

Normally, Line Identities will only be required of a DDI PBX. An option must be defined so that line identities will be supplied when necessary.

### Line Identity Digit Conversion

If incoming digit conversion is required to terminate DDI calls, then this conversion must be reversed when line identities are being supplied to the ISDN.



## Trunk Identities

When used with DPNSS1, a “trunk identity” will be used for originating/called line identity exchange and display purposes, for DPNSS1 calls.

## Example of a DASS2 Numbering Scheme

Figure 5 illustrates a basic application of a DASS2 numbering scheme.

**Figure 5**  
**DASS2 typical numbering scheme**

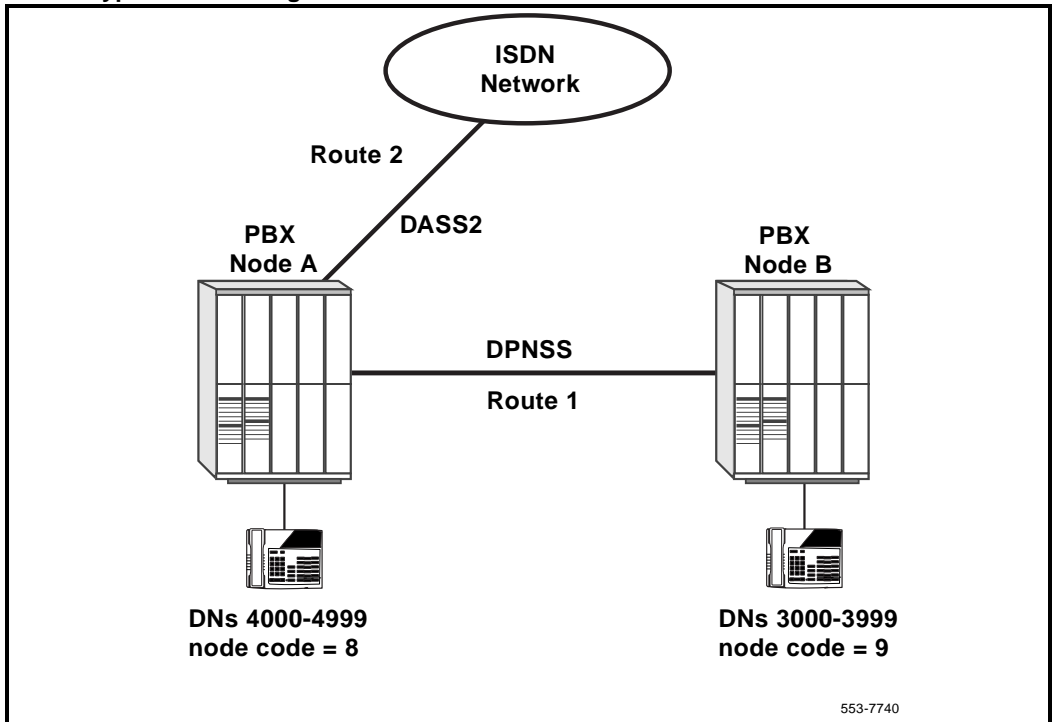

The PBXs are identified by node codes 8 and 9. In this example figure, the Network Access Code is 5. To place a call to a remote extension, the following digit fields must be dialed:

Network Access Code (5) + node code (8) + DN (4000 - the desired extension at the remote node.)

To make a local call the Network Access Code and node code part of the number can be omitted.

Access to the PSTN via the node A DASS2 route is obtained by dialing “9” followed by the required PSTN number. This applies to both nodes A and B. However, ISDN numbers 5541xx and 5542xx are the PSTN DDI numbers for extensions on nodes A and B respectively. The numbering plan ensures that calls to these numbers originated from within the private network are not routed via the DASS2 route (and thus do not incur call charges).

For incoming DASS2 DDI calls from the PSTN, three digits are received which must be converted into an internal network number. The sequence 1xx corresponds to the last three digits of a DN at node A, and 2xx to the last three digits of a DN at node B. Note that the Incoming Digit Conversion (IDC) feature can be used to provide flexible mapping from received digits to internal DNs. In this case the simplest mapping is chosen. 1xx maps to DNs 41xx on node A, and 2xx to DNs 32xx on node B. No other extensions on the network are accessible using DDI.

### **Digit Insertion**

At both nodes, the DPNSS1 route is programmed to insert a leading digit of “5” (using the INST prompt in Overlay 16), the network access code, for all incoming calls. The same effect could have been achieved by using Digit Manipulation at the originating end of the DPNSS1 call to insert the “5”. The advantage of the method chosen is that configuration data relating to the network access code of node A is restricted to A (or B); thus if the access code should be changed, node A is the only node where reprogramming would be needed.

## **Dialing Network Numbers**

Routing of calls from one network node to an extension on the other node is done using the CDP feature. The network coordinated dialing plan DN length is six digits. Essentially, CDP is used to synthesize a location code dialing plan. The network access code, “5”, and the node location codes, “8” and “9”, are absorbed into the programmed distant steering codes and local steering codes.

Table 2 and Table 3 provide examples of how distant steering codes and local steering codes are applied.

**Table 2**  
**Distant Steering Codes application**

PBX A					PBX B				
DSC	RLI	Route	DMI		SPN	RLI	Route	DMI	
			Del	Ins				Del	Ins
59	101	1	1	-	58	201	1	1	-

**Table 3**  
**Local Steering Codes application**

PBX A			PBX B		
LSC	DMI		LSC	DMI	
	Del	Ins		Del	Ins
584	2	-	59	2	-

A three digit local steering code, “584” is required at node A, in order to distinguish from the trunk steering code used to route calls incoming from node B to DASS2, “589”.

Figure 6 shows the digit processing performed to terminate a network call from a node B user dialing 5-8-4321 to reach extension 4321 at node A.

**Figure 6**  
**Network call termination**

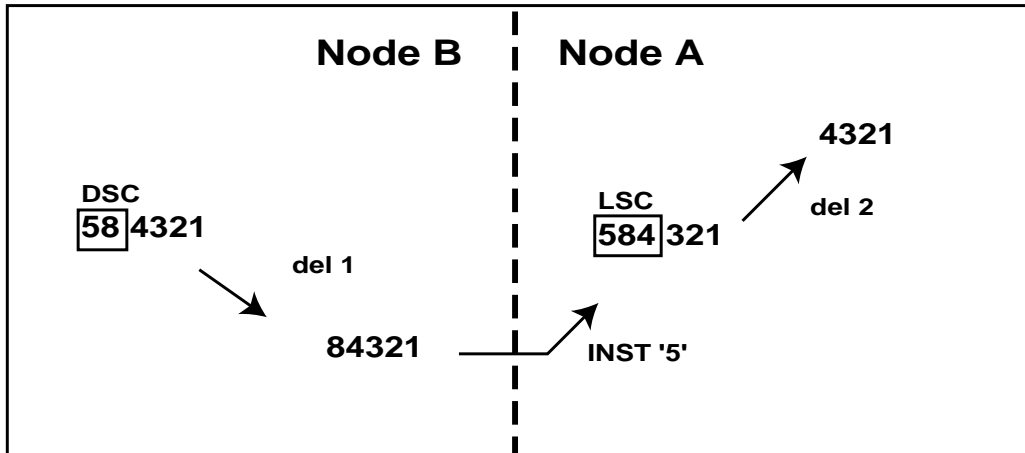

553-7739

## Dialing PSTN Numbers

PSTN numbers are handled using the BARS feature. The digit “9” is defined as the BARS access code at both nodes. A minimum of 10 Special Numbers will be programmed, “0”, “1”, “2”.....”9”. Note that calls to local PSTN numbers 5541xx and 5542xx must be programmed not to be routed onto the public network. These are DID extension numbers for PBXs A and B respectively. The Supplementary Digit Restriction/Recognition (SDRR) feature must be employed at both nodes to recognize these exceptions.

## Special Numbers

### Special Number programming at node A

On node A, “5” is programmed as one of several Special Numbers. The special number defines the routing for PSTN numbers which begin with the digit “5”. The basic programming for Special Number “5” is as shown in Table 4.

**Table 4**  
**Application of special number 5 at node A**

PBX A				
SPN	RLI	Route	DMI	
			Del	Ins
5	103	2	-	-

If the number 5541xx is dialed, this must be recognized as an extension 41xx local to PBX A. The digits must be manipulated so that the call can terminate directly on 41xx. A Supplementary Digit Restriction and Recognition (SDRR) table must be created for SPN “5”. In the table, an entry of type LDID (Local DID) must be programmed, with digit sequence “5541”. A digit manipulation must be associated with LDID entries in the SDRR table which will delete the two leading digits and then present the remaining digits to the local digit translator.

If the number 5542xx is dialed, this must be recognized as an extension 32xx local to PBX B. Alternative routing of the call is required to route the call directly to PBX B on route 1 without including an out and back PSTN leg. Digit manipulation is also required to convert 5542xx to 32xx. An SDRR entry of type ARRN (Alternative Routing) can be added to the table, for digit sequence "542". An alternative route list index must be entered which is shown in Table 5.

**Table 5**  
**Application of an alternative route list index for digit sequence 542**

SPN	Digit Sequence	Type	DMI		RLI
			Delete	Insert	
5	542	ARRN	-na-	-na-	104
	541	LDID	2	-	-na-

The alternative route list associated with the ARRN entry will be programmed as shown in Table 6.

**Table 6**  
**Application of an alternative route list associated with ARRN**

RLI	Route No	Digit Manipulation	
		Delete	Insert
104	1	3	593

### Special Number programming at node B

On node B, Special Number “5” is programmed as shown in Table 7.

**Table 7**  
**Application of Special Number 5 at node B**

PBX B				
SPN	RLI	Route	DMI	
			Delete	Insert
5	203	1	-	89

If the number 5542xx is dialed by an extension on node B, this must be recognized as the DID number of extension 32xx, local to node B. An SDRR table with an LDID (Local DID) entry “542” must be created for SPN “5”.

If the number 5541xx is dialed by an extension on node B, this must be recognized as the DID number of extension 41xx, local to node A. While the call should still be routed to node A, digit manipulation is required so that the call does not tandem through node A and out to the PSTN. An SDRR entry of type DID can be added to the table, for digit sequence “541” which will provide a unique digit manipulation for this digit sequence, to turn the digits into the internal DN of the extension dialed. Refer to Table 8.

**Table 8**  
**Application of an alternative route list index for digit sequence 541**

SPN	Digit Sequence	Type	DMI		RLI
			Delete	Insert	
5	541	DID	2	8	-na-
	542	LDID	3	3	-na-

When the 5541xx special number is dialed from node B, the digits received at node A will be translated using to the coordinated dialing plan feature. Figure 7 shows the full sequence of digit conversion.

Figure 7  
Digit conversion, node A and node B

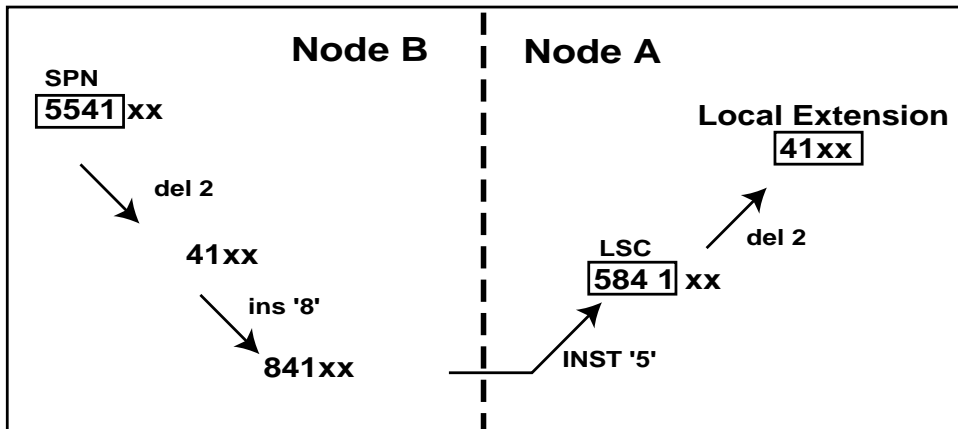

553-7744

The digits which are analyzed at node A, “5841xx”, equate to the local steering code “584”. The two leading digits are deleted to give the node A local extension number.

When another Special Number is dialed from node B, the digit manipulation at node B and the INST on the DPNSS1 route at node A combine to generate a trunk steering code which routes calls to the DASS2 route. This is shown in Figure 8.



Figure 8  
Generation of a trunk steering code

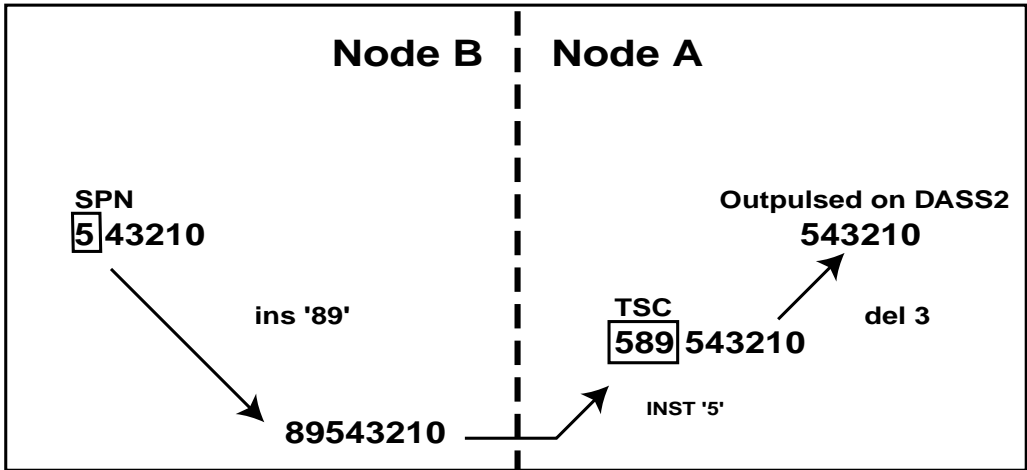

553-7743

### **PSTN Number Barring**

There may be a requirement to allow callers to dial certain PSTN numbers whilst barring others. For example, network callers may be allowed to dial PSTN numbers within the UK, but are barred from international dialing. To achieve this, Special number '0' can be defined and entered in an associated SDRR table as a DENY, (that is, barred) entry. Note that a sequence which may not be defined is '01', (that is, 010, which is the international dialing code). There may be a requirement to allow callers to dial certain PSTN numbers whilst barring others.

Alternatively, there may be a requirement to bar PSTN dialing outside of the local area, with the exception of a few area codes. For example, if users are to be allowed to make local PSTN calls and calls to London, Liverpool, Birmingham and Manchester only, then the following Special Numbers would be defined:

- 021- Birmingham
- 051- Liverpool
- 061- Manchester
- 071- Inner London
- 081- Outer London
- 1- Local
- 2- Local
- 3- Local
- 4- Local
- 5- Local
- 6- Local
- 7- Local
- 8- Local
- 9- Local

## Routing of DDI Calls

An Incoming Digit Conversion (IDC) table must be assigned to the DASS2 route to convert the received “1xx” and “2xx” digit sequences. The “1xx” must be converted to the node A extension number “41xx”. The “2xx” is converted to the CDP DN which will permit routing and termination on the node B extension “32xx”. Refer to Table 9.

**Table 9**  
**Application of an incoming digit conversion table**

IDC for DASS2 DDI on PBX A	
Received Digit	Convert to
1xx	41xx
2xx	5932xx

## Programming for ISDN Line Identities

Most of the programming for ISDN line identities must be done at node A. At node B, only the ISDN access code, “9”, needs to be programmed. At node A, a digit conversion table is required to reverse the Incoming Digit Conversion performed on DDI calls on the DASS2 route. This conversion will provide the ISDN with consistent line identities. Refer to Table 10.

**Table 10**  
**Application of a Line Identity conversion table**

Line ID Digit Conversion Table	
Internal Digits	Convert to
41xx	1xx
5932xx	2xx

Note that if a non-DDI extension on either node makes an outgoing call to the ISDN, no line identity will be supplied by the private network. The ISDN must provide a default line identity.



---

# Hardware requirements

---

## DASS2 hardware requirements

The following hardware is required for each DASS2 link on Meridian 1 system Options 21, 21E, 51/51C, 61/61C, 71, and 81/81C:

- one NTAG54 Dual Daughterboard (for NTCK43AB or higher vintages of the Dual PRI)

or

- one NT5K35 D-channel Handler Interface

or

- one NT5K75 D-channel Handler Interface - an enhanced version of the NT5K35 which provides up to 160 D-channel port addresses. This card supports two switch-selectable modes of operation — standard mode and expanded mode. Standard mode D-channels may be assigned an input/output port address in the range 0-15; expanded mode D-channels may be assigned port addresses in the range 0-159. Each port has a set of DIP switches allowing full configuration flexibility. **Please see the section entitled “Engineering note pertaining to port addressing modes” on page 41 in this chapter.**

or

- one NT6D11AE/AF D-channel Handler Interface - an enhanced version of the NT5K75 which is fully backward compatible with the NT5K75 and NT5K35. This card supports two switch-selectable modes of operation — standard mode and expanded mode. Standard mode D-channels may be assigned an input/output port address in the range 0-15; expanded mode D-channels may be assigned port addresses in the range 0-159. Each port has a set of DIP switches allowing full configuration flexibility. **Please see the section entitled “Engineering note pertaining to port addressing modes” on page 41 in this chapter.**

*Note:* The NT5K75 and NT6D11AE/AF cannot operate in expanded addressing mode on Meridian 1 Options 21 and 21E.

- one NTCK43 dual-port PRI card (NTCK43AB or higher)

or

- one NT8D72 Primary Rate Interface card (NT8D72BA is required for EuroISDN applications)
- one QPC949D CPU ROM (up to and including Group G) and NTND08AA CPU ROM (up to and including Group H) are required to support the expanded capability of the NT5K75 and NT6D11AE/AF DCHI
- one loop of the QPC414 ENET dual loop network interface card

- one of the following cables:
  - NT5K40AA PRI to Line Terminating Equipment cable (15 pin D-type to twin BNC, 4 meters)
  - NT5K41AA PRI to Line Terminating Equipment cable (15 pin D-type to twin BNC, 8 meters)
  - NT5K86AA PRI to Line Terminating Equipment cable (15 pin D-type to twin BNC, 12 meters, TX shield connected to FGND)
  - NT5K86BA PRI to Line Terminating Equipment cable (15 pin D-type to twin BNC, 12 meters, RX shield connected to FGND)
  - NT5K86AA PRI to Line Terminating Equipment cable (15 pin D-type to twin BNC, 12 meters, TX and RX shields connected to FGND)
- one QCAD328 DCHI to PRI cable
- one NT8D85 ENET to PRI cable

- for the NTCK43 DPRI card, the following cables are used:
  - NTCK45AA 120 Ohm Dual PRI to I/O Panel cable (8ft)
  - NTCK78AA 120 Ohm Dual PRI cable for ST Machines (50ft)
  - NTCK79AA 75 Ohm Dual PRI Coax Cable (40ft)
  - NT8D7217 Dual PRI I/O Panel to Multiplexer cable (50ft)
  - NTCK46AA Dual PRI to DASS/DPNSS NT6D11 DCHI cable (6ft)
  - NTCK46AB Dual PRI to DASS/DPNSS NT6D11 DCHI cable (18ft)
  - NTCK46AC Dual PRI to DASS/DPNSS NT6D11 DCHI cable (35ft)
  - NTCK46AD Dual PRI to DASS/DPNSS NT6D11 DCHI cable (50ft)
  - Clock Controller cables (1 to 2 port cables):
    - NTCK47AA Dual PRI to Clock Controller cable (2ft)
    - NTCK47AB Dual PRI to Clock Controller cable (4ft)
    - NTCK47AC Dual PRI to Clock Controller cable (6ft)
    - NTCK47AD Dual PRI to Clock Controller cable (8ft)
    - NTCK47AE/AF Dual PRI to Clock Controller cable (10ft)
  - Clock Controller Cables (1 to 4 port cables)
    - NTCK81AA Dual PRI to Clock Controller cable (2ft)
    - NTCK81AB Dual PRI to Clock Controller cable (4ft)
    - NTCK81AC Dual PRI to Clock Controller cable (6ft)
    - NTCK81AD Dual PRI to Clock Controller cable (8ft)
    - NTCK81AE/AF Dual PRI to Clock Controller cable (10ft)



- one QPC775 Clock Controller (QPC775E is required on Option 81/81C machines, and where EuroISDN functionalities are being supported). This cable is required if the DPNSS1 loop is to be used as a timing synchronization source for the Meridian 1 PBX.
- one NT8D79AD PRI to Clock Controller cable. This cable is required if the DPNSS1 loop is to be used as a timing synchronization source for the Meridian 1 PBX.

**Note:** Presently, the network loop used for DASS2 cannot be odd-numbered if the associated even-numbered loop is programmed as being used for existing peripheral equipment, that is, as TERM, TERD, or TERQ in Overlay 17. If all peripheral equipment is IPE, this constraint applies only when Meridian Mail is equipped. Refer to Table 11.

**Table 11**  
**Programming network loops**

<b>ENET Loop</b>	<b>Allowed</b>					<b>Not Allowed</b>
Even	Meridian Mail	PRI	PRI	Any	---	Meridian Mail
Odd	Meridian Mail	PRI	Meridian Mail	---	Any	PRI

### **Engineering note pertaining to port addressing modes**

There is a distinction between functionality regarding port addressing modes in Group G and earlier, and Group H and later.

#### **Group G and earlier**

Standard address mode (0-15) can be any of the following:

- DPNSS1 (DDSL)
- DASS2 (DDSL)
- APNSS (LSSL)
- Q931 (DCHI)
- ISL (DCHI)

- SDI
- ESDI

Expanded address mode (0-159) can be either of the following:

- DPNSS1 (DDSL)
- DASS2 (DDSL)

The expanded mode addressing has no impact on the standard mode addressing, that is, DASS2 D-channel (DDSL) 7 in the expanded mode can exist with the Q931 D-channel (DCHI) 7 in the standard mode.

Theoretically, it is possible to have 160 DASS2 D-channels and 16 other I/O devices. In practise, however, there is a limit of 40 addresses in expanded mode and 16 in standard mode, for a total of 56 addresses.

The port address numbers assigned to the NT5K75 and NT6D11AE/AF operating in expanded mode must not conflict with addresses assigned to other I/O port types. To avoid potential conflicts and to simplify system configuration, it is recommended that, in the expanded mode, the port addresses for the NT5K75 and NT6D11AE/AF avoid the standard mode range (0-15) and be numbered in the range 16-159 instead.

### **Group H and later**

Standard address mode (0-15) can be any of the following:

- DPNSS1 (DDSL)
- DASS2 (DDSL)
- APNSS (LSSL)
- Q931 (DCHI)
- ISL (DCHI)
- SDI
- ESDI

If the MSDL is used, standard mode can have a range of 0-63, and can be any of the following:

- Q931 (DCHI)

- ISL (DCHI)
- ESDI

Expanded address mode (0-159) can be either of the following:

- DPNSS1 (DDSL)
- DASS2 (DDSL)

The expanded mode addressing has no impact on the standard mode addressing, that is, DASS2 D-channel (DDSL) 7 in the expanded mode can exist with the Q931 D-channel (DCHI) 7 in the standard mode.

Theoretically, it is possible to have 64 addresses using the MSDL with Q931, ISDL, or ESDI, plus 160 addresses using the expanded mode for DPNSS1 for a total of 224 addresses. In practise, however, there is a limit of 64 addresses using MSDL with Q931, ISDL, or ESDI, plus 40 addresses using the expanded mode for DASS2, for a total of 104 addresses.

Presently, MSDL does not support SDI ports on DASS2, so the likely configuration would involve a mixture of standard mode addressing, MSDL addressing, and expanded mode addressing for DPNSS1. Such an example could be as follows:

- 0-7 (8 addresses) in the standard mode;
- 8-15 (32 addresses) in the MSDL mode;
- 16-55 (40 addresses) in the expanded mode.

The port address numbers assigned to the NT5K75 and NT6D11AE/AF operating in expanded mode must not conflict with addresses assigned to other I/O port types. To avoid potential conflicts and to simplify system configuration, it is recommended that, in the expanded mode, the port addresses for the NT5K75 and NT6D11AE/AF avoid the standard mode range (0-15) and be numbered in the range 16-159 instead.

Figure 9 illustrates a typical DASS2 hardware configuration.

Figure 9  
A typical DASS2 hardware configuration

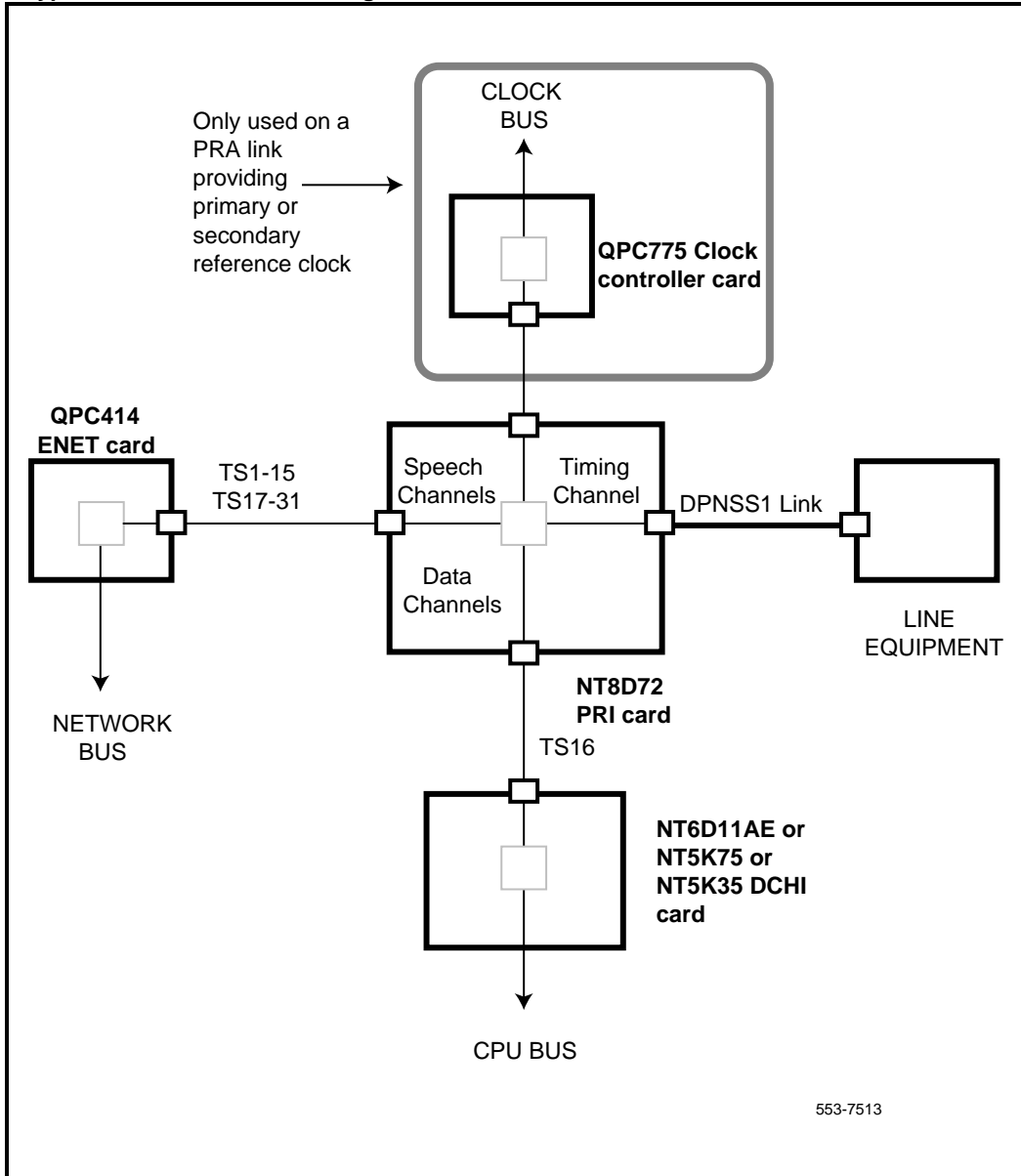



Meridian 1

**DASS2**

## Product Overview Guide

Copyright ©1992–2000 Nortel Networks

All Rights Reserved

Information is subject to change without notice. Nortel Networks reserves the right to make changes in design or components as progress in manufacturing and engineering may warrant. Please consult with your Nortel Networks representative regarding market specific regulatory requirements.

SL-1 and Meridian 1 are trademarks of Nortel Networks.

Publication number: 553-3911-100

Document release: Standard 6.00

Date: April 2000

Printed in Canada



*How the world shares ideas.*